

SL75

**SL75**  
**TECHNICAL DRAWINGS**



# MASS & DIMENSIONS

SL75

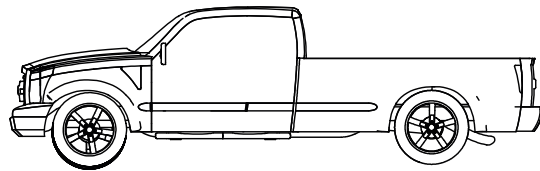
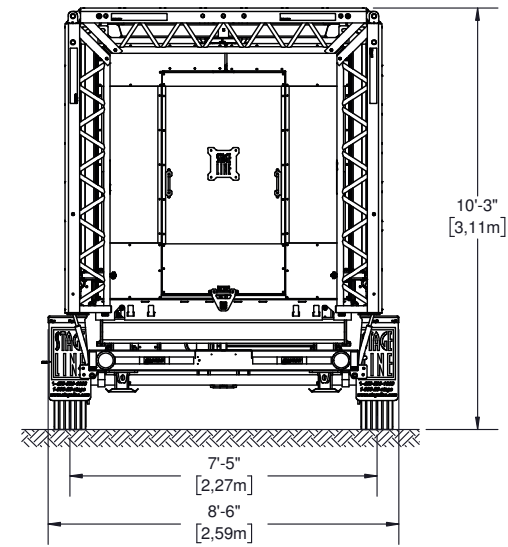
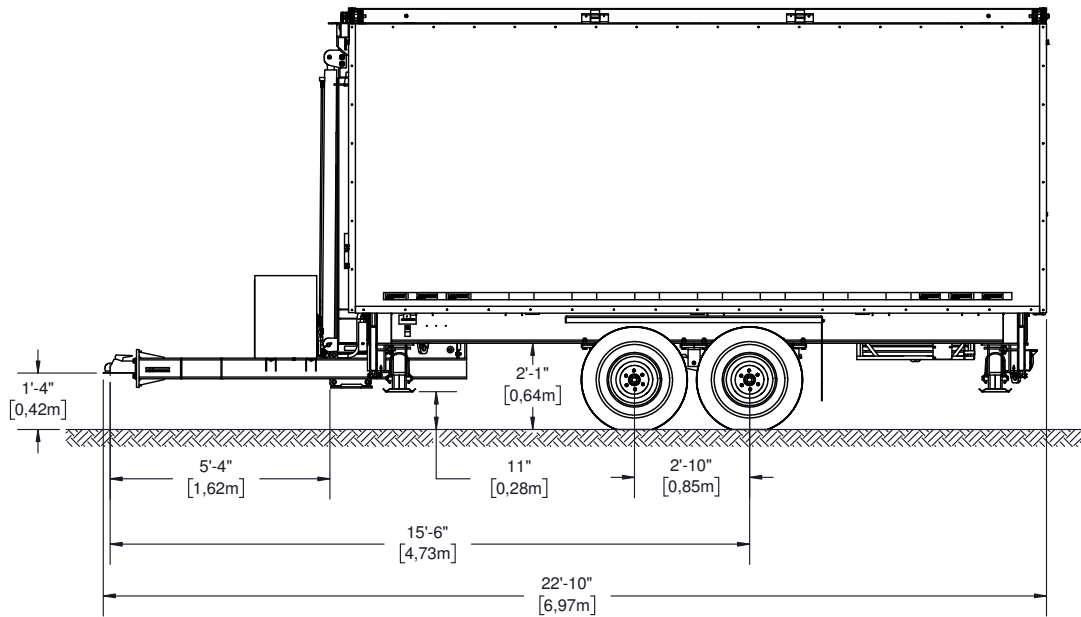

	UNLADEN WEIGHT		STANDARD EQUIPMENT		MAXIMUM CAPACITY	
	LB	KG	LB	KG	LB	KG
Total	6 722	3 050	8 540	3 875	13 750	6 237
Axle	6 019	2 731	7 600	3 448	12 000	5 443
Hitch	703	319	940	427	1 750	794

# FRONT VIEW

SL75

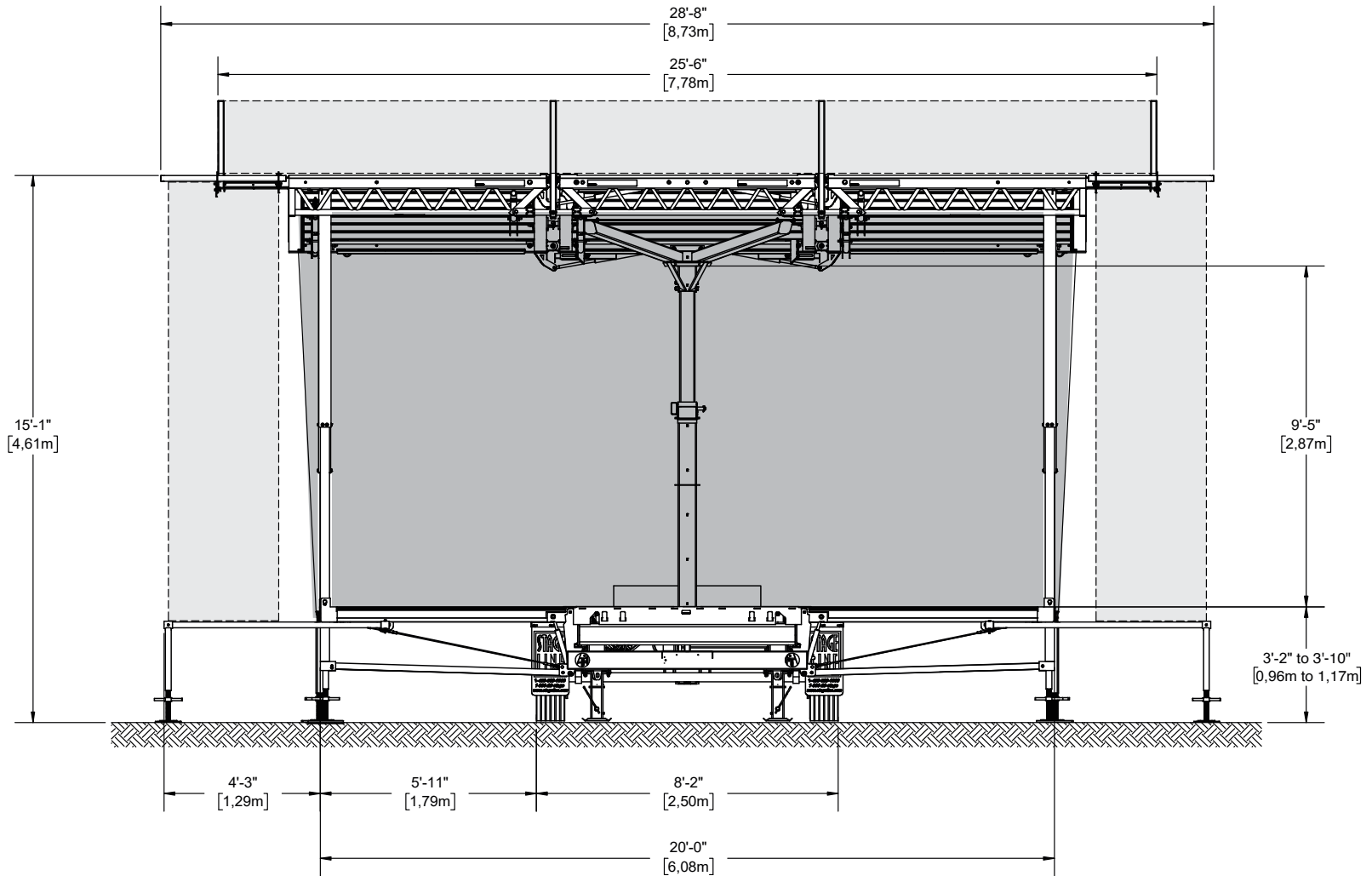

- Windwall
- Banner (For dimensions, please refer to *Banner Book*)

**STAGELINE** Drawings may show stage equipped with optional accessories. May be sold separately.  
 © 2023 - All rights reserved, Stageline Mobile Stage Inc. Any and all forms of adaptation or reproduction of this document including the plans and drawings, in whole or in part, are strictly forbidden without the written authorisation of Stageline Mobile Stage Inc. Mass may vary depending on options.  
 Technical specifications may change without notice. Stage specifications are subject to change without notice. Figures are nominal.

# FRONT VIEW WITH BANNERS

SL75

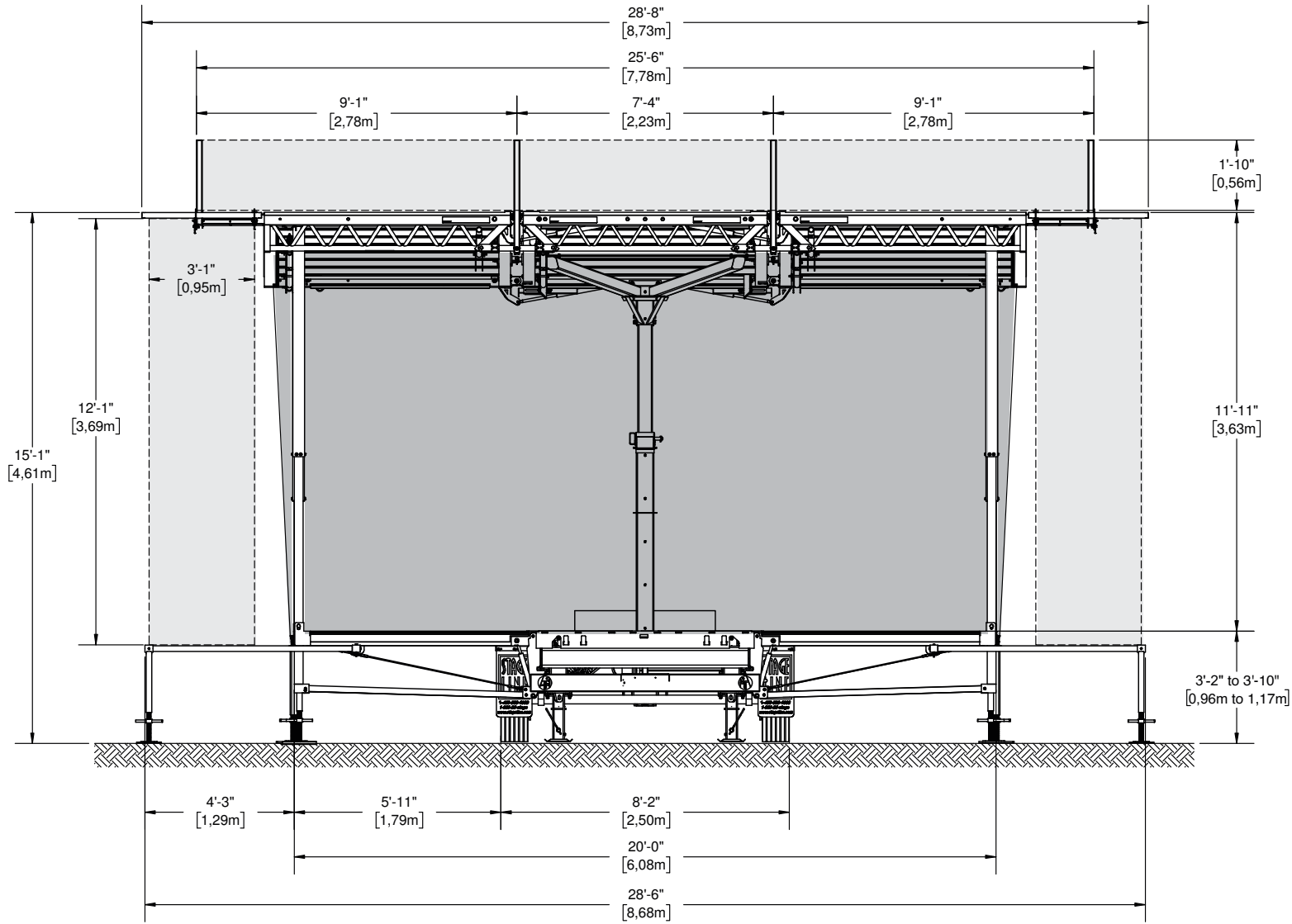

- Windwall
- Banner (For dimensions, please refer to *Banner Book*)

**STAGELINE** Drawings may show stage equipped with optional accessories. May be sold separately.  
 © 2023 - All rights reserved, Stageline Mobile Stage Inc. Any and all forms of adaptation or reproduction of this document including the plans and drawings, in whole or in part, are strictly forbidden without the written authorisation of Stageline Mobile Stage Inc. Mass may vary depending on options. Technical specifications may change without notice. Stage specifications are subject to change without notice. Figures are nominal.

# SIDE VIEW

SL75

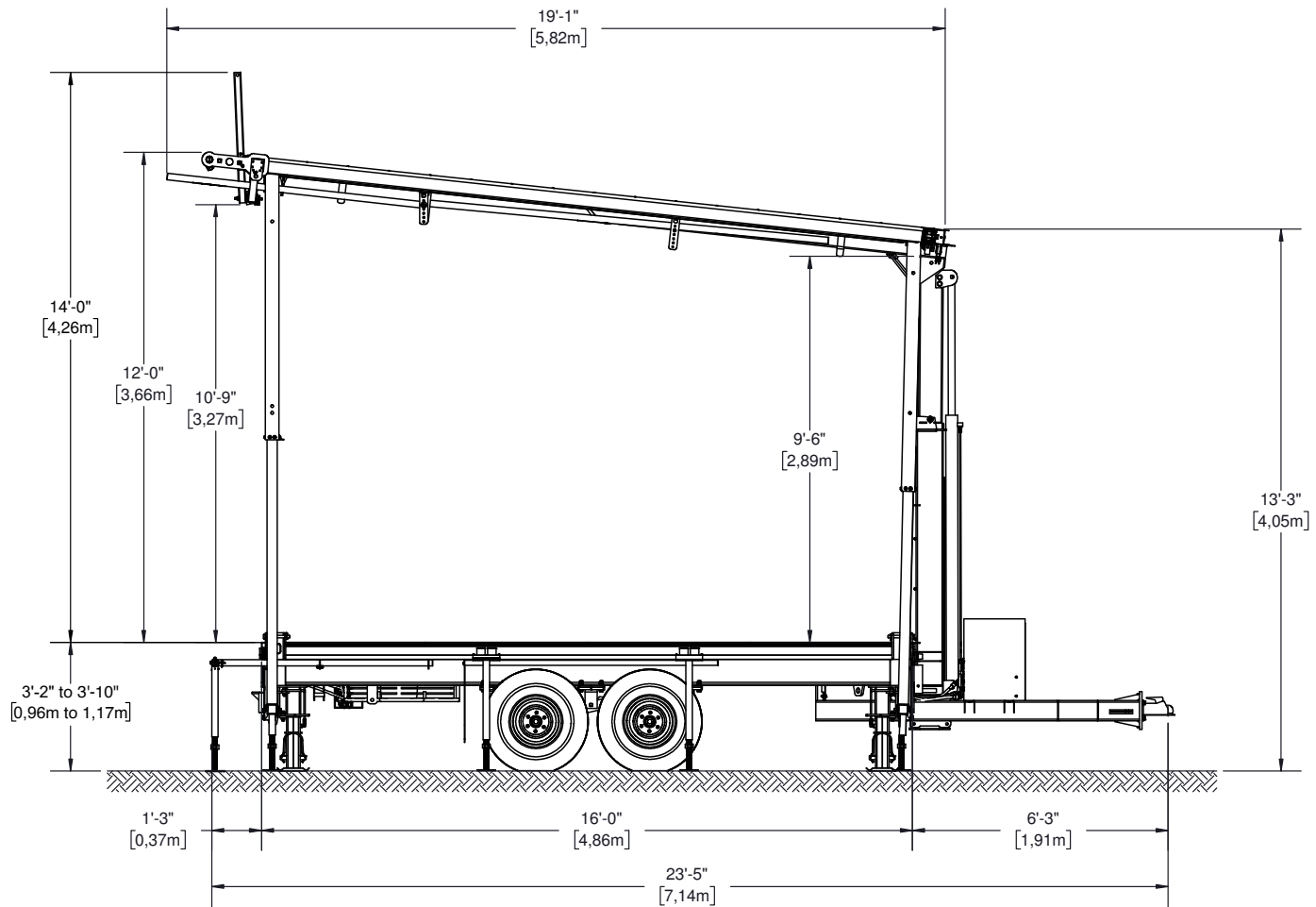

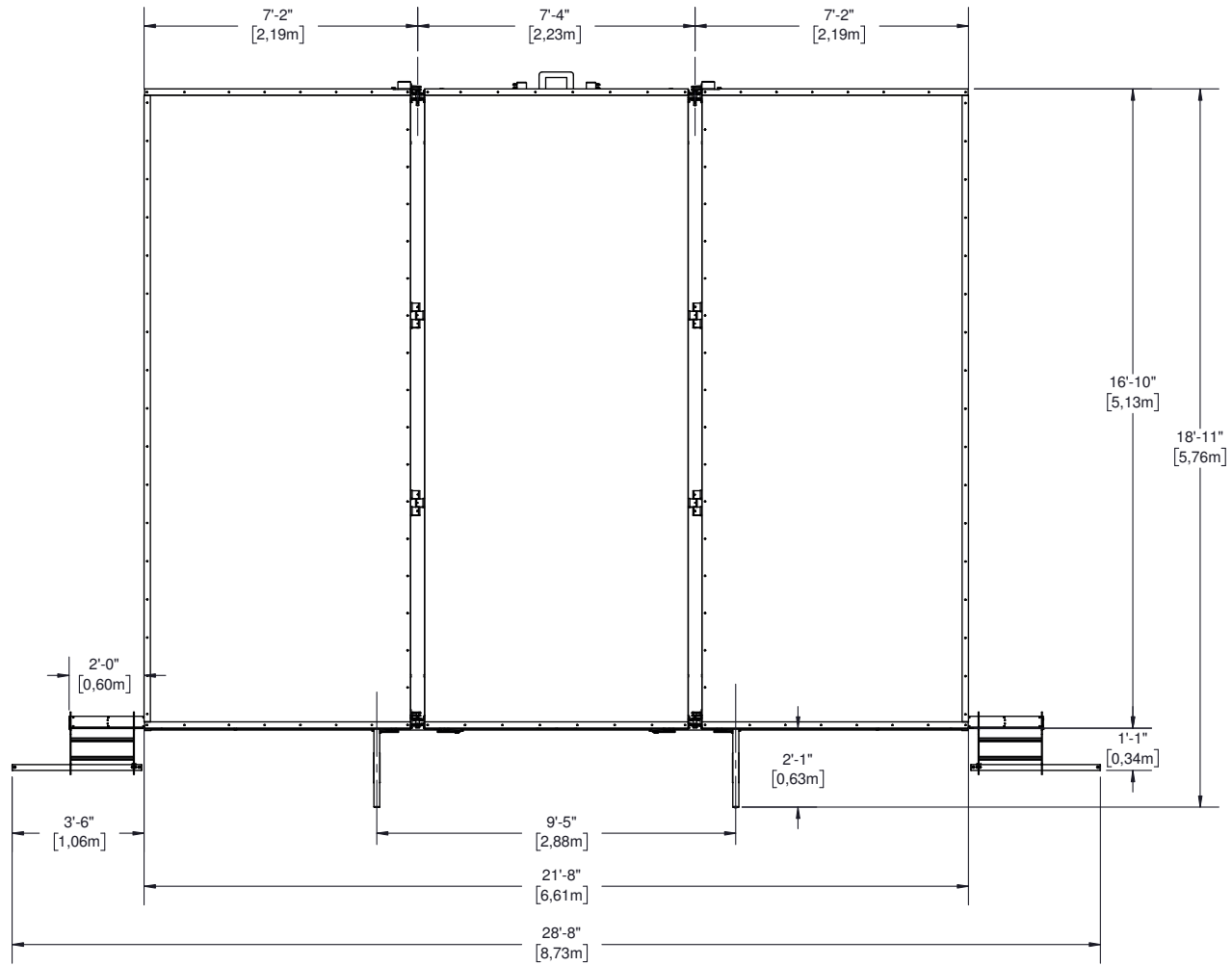

DOWNSTAGE

# FLOOR VIEW

SL75

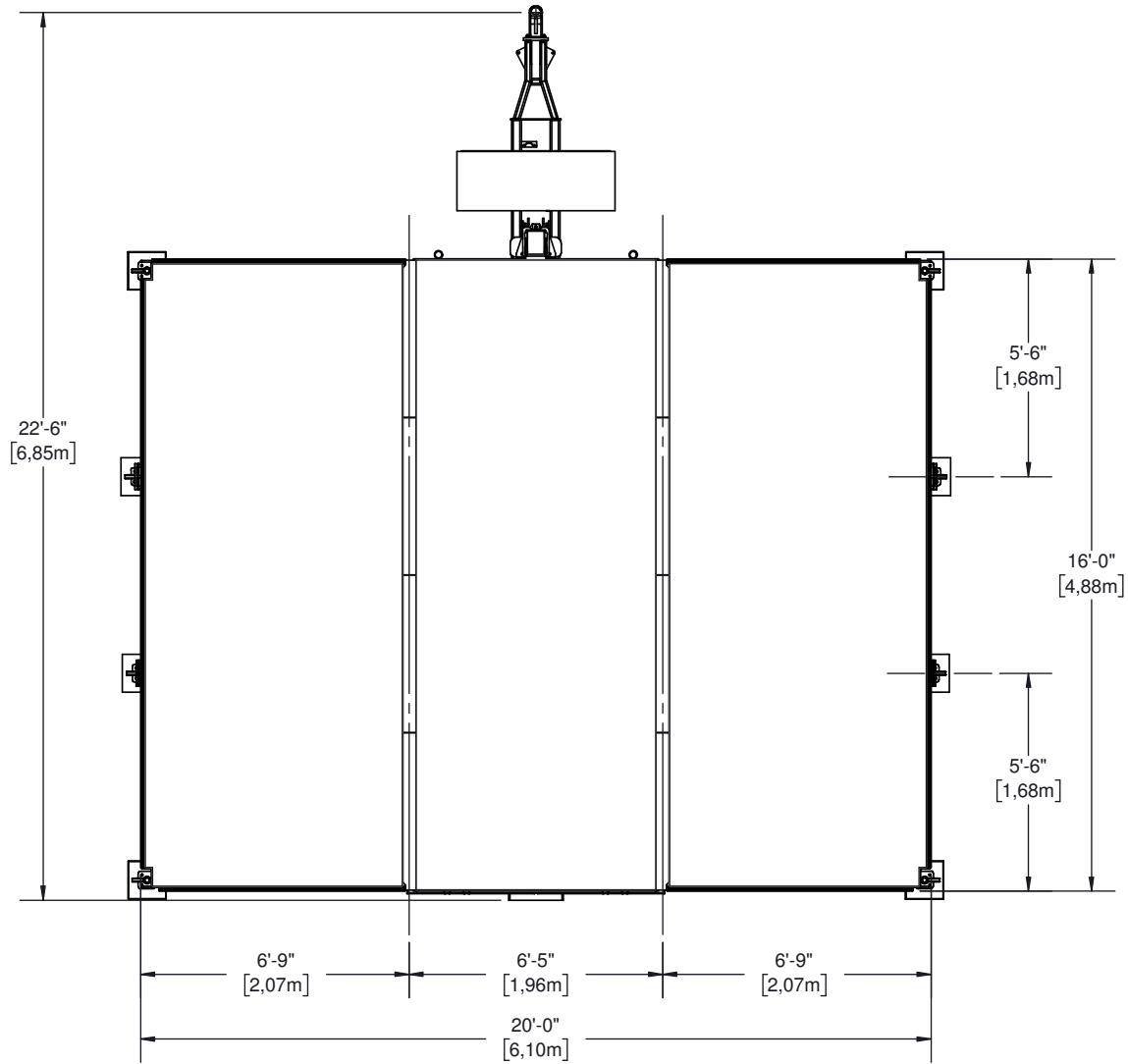

DOWNSTAGE

CAPACITY: 150 lb/ft<sup>2</sup> [732 kg/m<sup>2</sup>]

**STAGELINE** Drawings may show stage equipped with optional accessories. May be sold separately.  
© 2023 - All rights reserved, Stageline Mobile Stage Inc. Any and all forms of adaptation or reproduction of this document including the plans and drawings, in whole or in part, are strictly forbidden without the written authorisation of Stageline Mobile Stage Inc. Mass may vary depending on options.  
Technical specifications may change without notice. Stage specifications are subject to change without notice. Figures are nominal.

SL75 Gen1Gen2 Tech drawings | SMS2520 R1  
stageline.com | info@stageline.com

# EXTENSION PLATFORM LAYOUTS

SL75

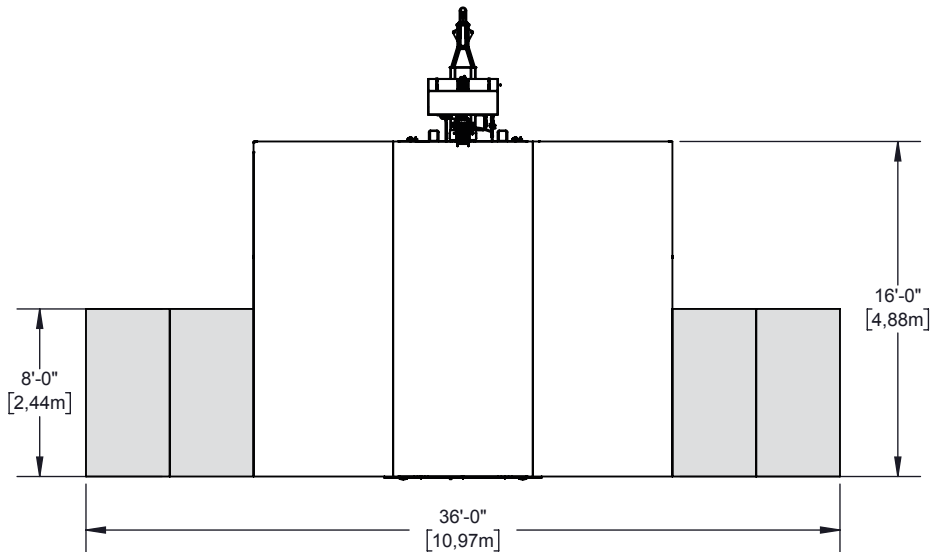
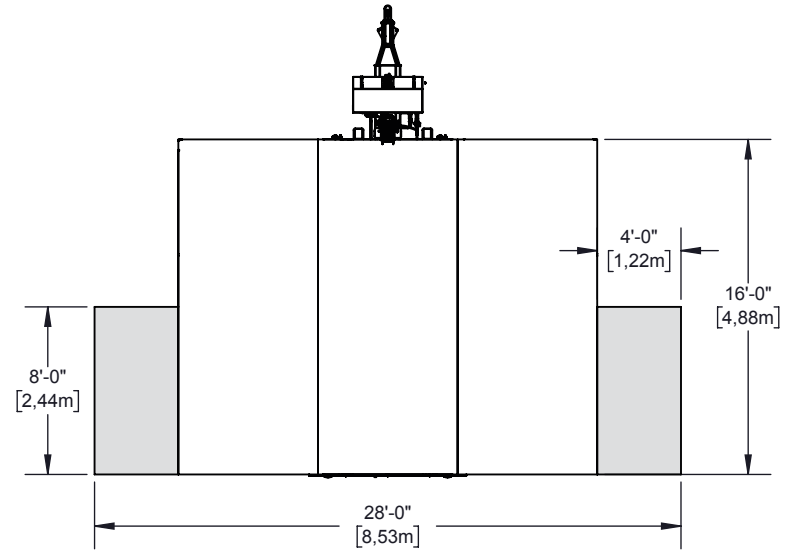
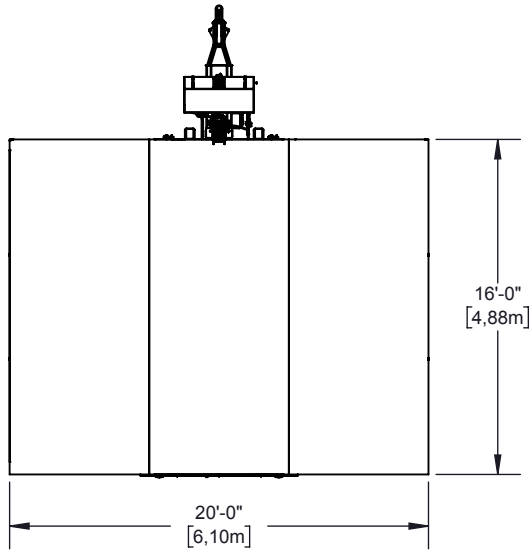

Platform

# RIGGING PLAN

1/4

SL75

**A THOROUGH UNDERSTANDING OF THE INTER-RELATED LOADINGS SHOWN IN THIS RIGGING PLAN IS NEEDED IN ORDER TO SAFELY USE THIS MOBILE STAGE ROOF AND TAKE FULL ADVANTAGE OF THE MANY RIGGING OPPORTUNITIES IT OFFERS.**

This mobile stage roof offers a variety of rigging options with regard to load capacity, placement and type.

There are rigging pipes, trusses, roof rigging points and side overhang rigging beams.

This rigging plan locates and defines these rigging features, includes load capacity for each and describes maximum combinations of loads amongst features.

Take note of exclusions, maximum sub-totals in a group, load balance requirements, maximum lifting capacity of roof and maximum rigging load on roof.

The maximum load on the roof is less than the sum of the maximum load on each rigging feature.

**Refer to *Operator's Manual* for procedures in regard to proper setup and setup methods of the stage and its options.**

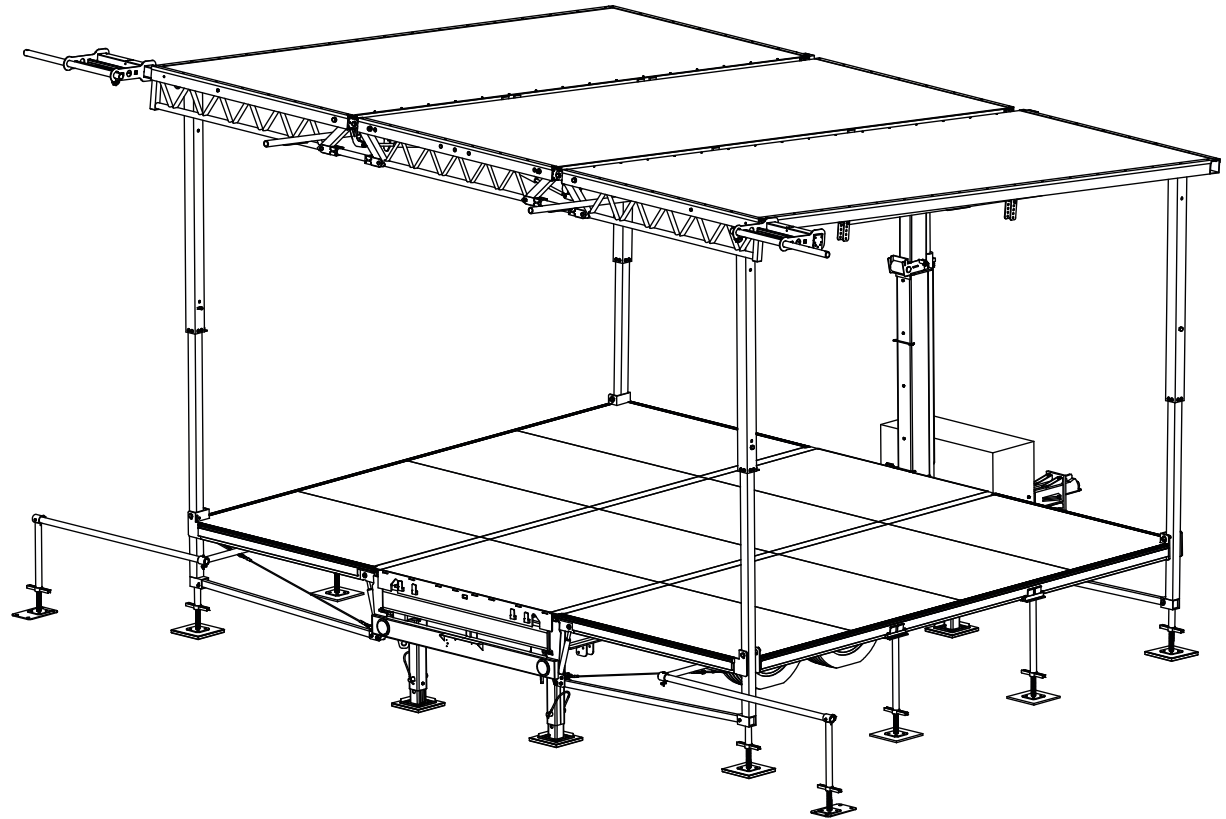

The information contained in the current document is final and must be considered as such. They are derived from design briefs and summarized to help the user plan rigging configurations safely. It is therefore mandatory that the user follows and respects the capabilities and limitations described herein. Overloading of stage components above their specified capacity may result in structural failure, equipment damage, injury or death. Stageline cannot be held responsible if the user, himself or subcontractors under his supervision, derogate from this document and/or the approved rigging plan. If a desired configuration cannot meet these requirements, the user must contact Stageline to analyse the case and obtain further instructions. Special restrictions and limitations may apply.

Certain authorities may require that a rig configuration plan, signed and sealed by a recognized member of a professional body, be available to allow the stage to be setup on their territory. This document was not intended to and cannot be used or considered as an official document or certificate to serve this purpose. Contact responsible authorities or Stageline for details.



Drawings may show stage equipped with optional accessories. May be sold separately.  
© 2023 - All rights reserved. Stageline Mobile Stage Inc. Any and all forms of adaptation or reproduction of this document including the plans and drawings, in whole or in part, are strictly forbidden without the written authorisation of Stageline Mobile Stage Inc. Mass may vary depending on options.  
Technical specifications may change without notice. Stage specifications are subject to change without notice. Figures are nominal.

# RIGGING PLAN

2/4

SL75

## RIGGING RESTRICTIONS

- **MAXIMUM LOAD BEARING CAPACITY:** 4 250 lb (1 930 kg). All corner posts and telescopic columns must be installed, pinned and secured.
- Each truss area can be loaded to a maximum of 250 lb (113 kg). Point capacity in each area must be respected.
- In the front truss zones, any point indicated by an arrow can be used. TL truss zone must be symmetric with TR truss zone. Each zone has a maximum capacity of 250 lb (113 kg).
- A maximum of 125 lb (57 kg) can be loaded at any place along each FOH.
- Do not load more than 30 lb/lin. ft (45 kg/lin. m) per rigging pipe with a maximum load of 300 lb (136 kg).
- Rigging pipes can be installed at P1 to P8 points location. Point load capacity must be respected.
- Loads on P10s is 600 lb (272 kg) once all corner posts have been installed and lateral banners are installed. Capacity can be increased to 750 lb (340 kg) if all corner posts are installed and lateral banners are not installed.

## LIFTING RESTRICTIONS

- **MAXIMUM ROOF LIFTING CAPACITY:** 200 lb (91 kg)
- When lifting, make sure loads are evenly divided between right and left side of roof.

## WARNING

SERIOUS DAMAGE OR INJURY CAN OCCUR IF LIFTING CAPACITY IS EXCEEDED.

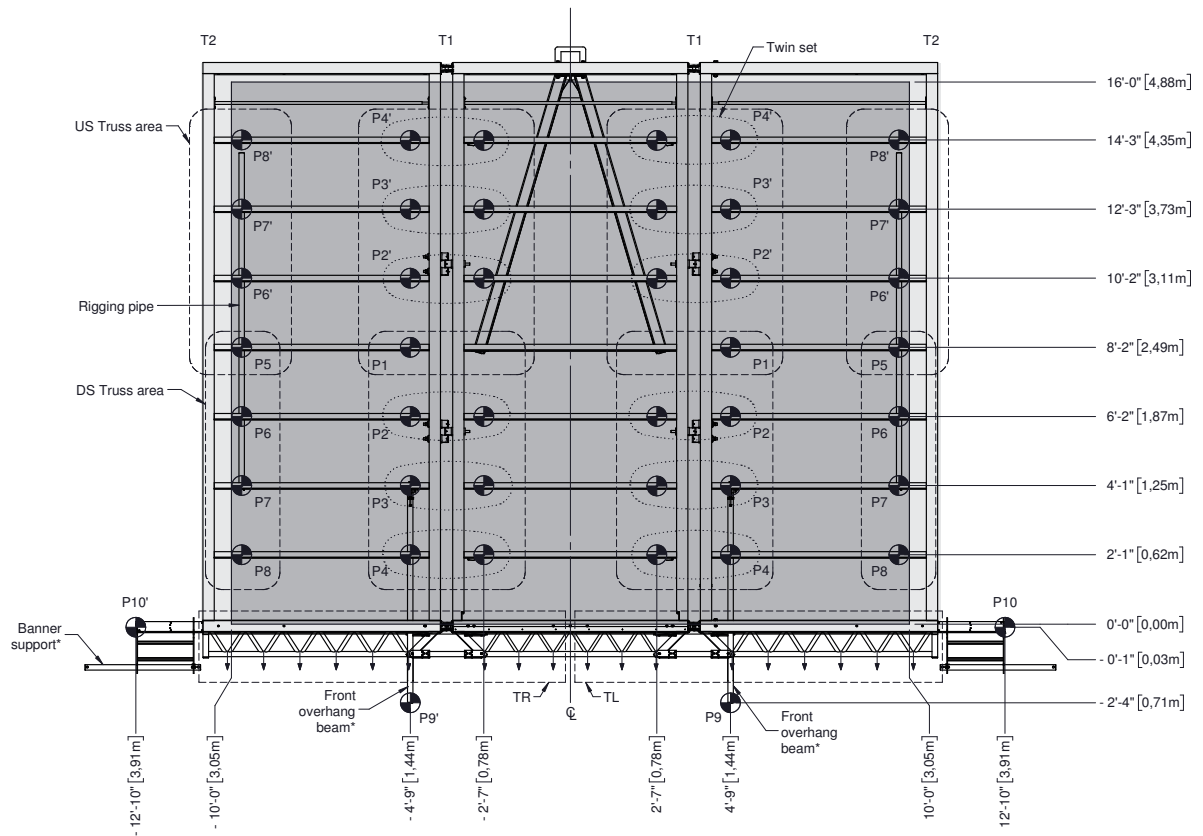

\* Optional items, see stage specifications.

# RIGGING PLAN

3/4

SL75

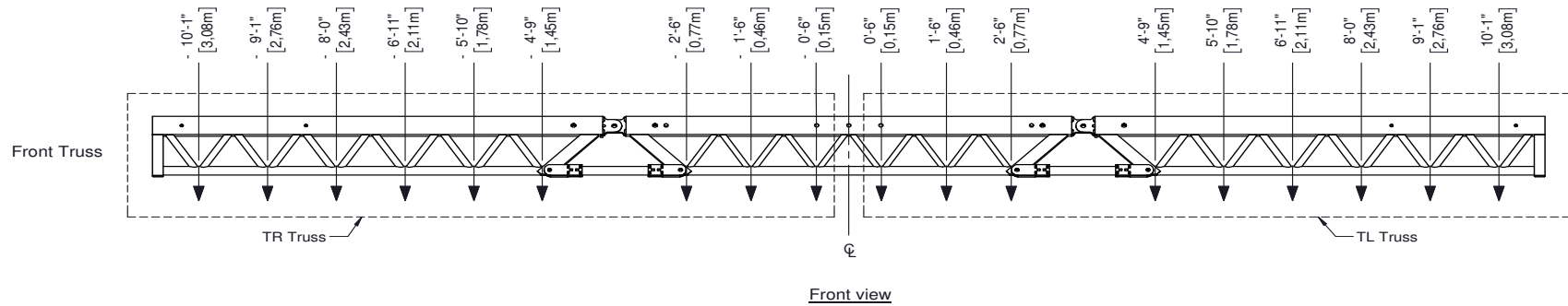

MAXIMUM LOAD CAPACITY		
POINT NO.	LB	KG
P1	250	113
P2 or P2', P3 or P3'	250	113
P4 or P4', P5	250	113
P6 or P6', P7 or P7'	250	113
P8 or P8'	250	113
P9*	125	57
P10	750	340
TL, TR	250	113

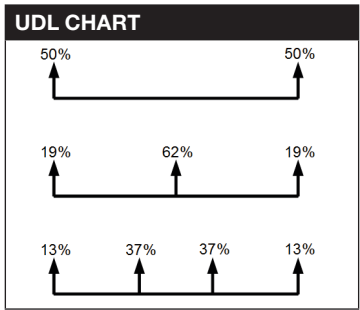

\* Optional items, see stage specifications.

## CALCULATION EXAMPLE

WHEN CALCULATING THE LOADS ON AN SL75, USE FOLLOWING METHOD:

- Calculate all the loads applied to each point.
- Verify the applicable limitations for each points.
- Verify the general applicable limitations.

LOAD CHART*		
POINT	LOAD CALCULATION	LOAD AT POINT (LB)
UST1	0.13 (13%, see UDL) x 400	52
UST2	0.37 (37%, see UDL) x 400	148
UST3	0.37 (37%, see UDL) x 400	148
UST4	0.13 (13%, see UDL) x 400	52
AUD1	400	400
AUD2	400	400
FT1	0.5 (50%, see UDL) x 200	100
FT2	0.5 (50%, see UDL) x 200	100
RP1	0.5 (50% of weight) x 90	45
RP2	0.5 (50% of weight) x 90	45
RP3	0.5 (50% of weight) x 90	45
RP4	0.5 (50% of weight) x 90	45

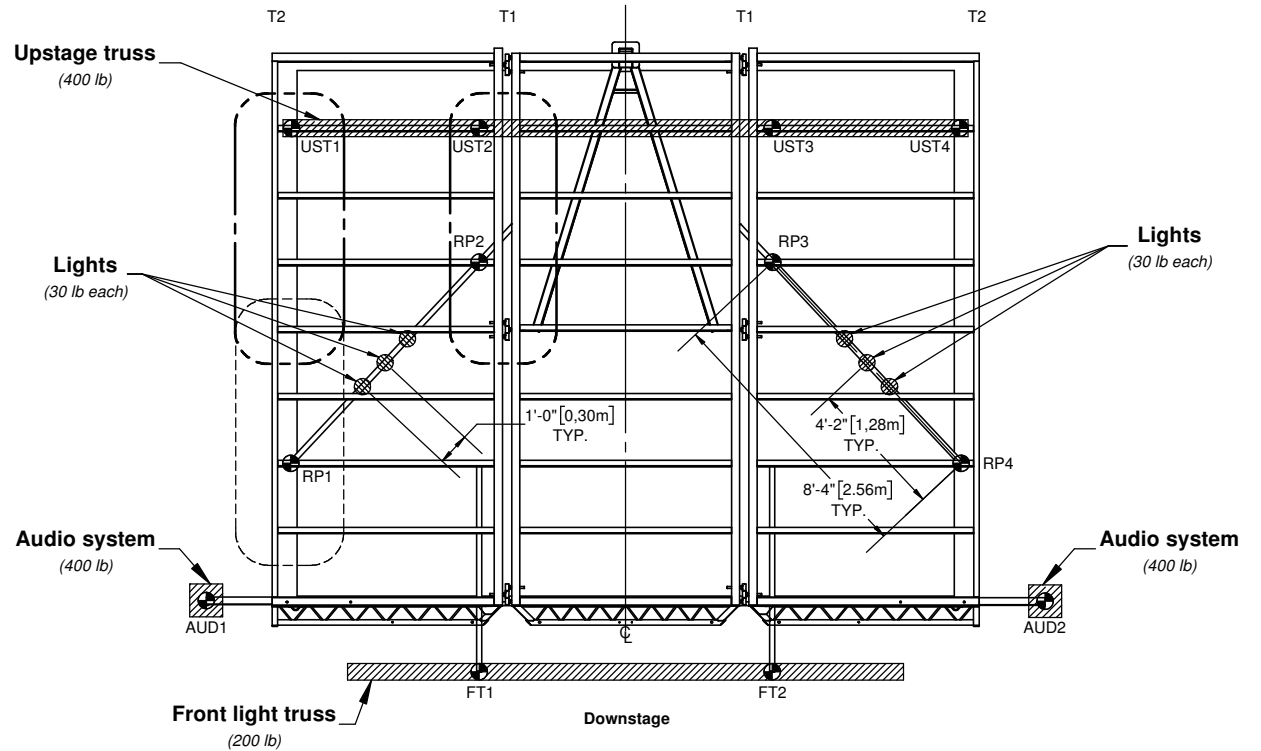

### POINT LOAD VERIFICATION

- Upstage truss:** UST1 to UST4 < 250 per rig point
- PA systems:** AUD1 and AUD2 < 750 (no banners installed)
- Front light truss:** FT1 and FT2 < 125
- Rigging pipes:** RP1 to RP4 < 250 per rig point

### RESTRICTIONS VERIFICATION

- T2** US area = UST1 = 52 < 250  
DS area = RP1 = 45 < 250
- T1** US area = UST2 + RP2 = 193 < 250
- Rigging pipes are not loaded more than 30 lb/ft

**So this rigging plot does not overload the roof and is considered acceptable.**

\* Refer to rigging plot.

827 L'Ange-Gardien Blvd., L'Assomption  
Quebec, Canada J5W 1T3  
**1 450.589.1063 / North America 1 800.267.8243**  
[stageline.com](http://stageline.com)

MOBILE STAGES | SALES & RENTALS

